

UPS Energy Storage Battery

User Manual



Product Name: 256V 25.6kWh / 512V 51.2kWh battery

Model No: H V P A C K 2 5 6 / 5 1 2 V

Version No: V1.0

Content

1. Safety Precautions	1
1.1 Note Before Installation.....	1
1.2 During Operation.....	2
2. System Application Introduction.....	2
2.1 PV Self-use Surplus Power to Grid	2
2.2 Peak Shaving and Valley Filling	2
2.3 Standby Power Supply	2
3. Product Specification.....	3
3.1Packing List.....	3
4. Battery Drawing	4
5. System Installation Instructions.....	4
5.1 Installation location	4
5.2 Installation Tools.....	5
5.3Installation steps	6
6. Appendix1.....	6
7. Appendix2.....	7

1.Safety Precautions

It is very important and necessary to read the user manual carefully before installing or using the battery. Failure to follow any of the instructions or warnings in this document can result in electrical shock, serious injury, or may damage the battery and the whole system.

The battery needs to be recharged within 12 hours after fully discharging.

Do not expose cable outside.

All battery terminals must be disconnected before maintenance.







Do not use cleaning solvents to clean the battery.

Do not expose the battery to flammable or harsh chemicals or vapors.

Any foreign object is prohibited to be inserted into any part of the battery.

Any warranty claims are excluded for direct or indirect damage due to items above.

If the battery is stored for a prolonged time, it is requirement that they are charged every three months, and the SOC should be no less than 30%.

Symbol	Description
	Caution, risk of electric shock
	Heavy enough may cause severe injure
	Keep the battery away from open flame or ignition sources
	Keep the battery away from children
	Do not dispose of the product with household waste
	Recycling
	Read this manual before installation and operation

1.1 Note Before Installation

When receiving, please check the system and packing list first, if the pack is damaged or spare parts are missing, please contact the dealer.

Before installation, be sure to cut off the grid power and make sure the battery is in the turned-off mode.

Wiring must be correct, do not mix-connect the positive and negative cables, and ensure no short circuit with the external device.

It is prohibited to connect the battery to AC power directly without an AC Breaker.

Please ensure the electrical parameters of AC power and Load are compatible to system.

Keep the system away from fire or water.

1.2 During Operation

If the system needs to be moved or repaired, the power must be cut off first and the battery is completely shut down;

It is prohibited to connect the system with different type of battery.

In case of fire, only dry powder fire extinguisher can be used, liquid fire extinguishers are prohibited.

Please do not open, repair, or disassemble the system. We do not undertake any consequences or related responsibility due to violation of safety operation or violating of design, production, and equipment safety standards.

2.System Application Introduction

This product is a household energy storage battery pack. The system is matched with a 23.0/51.2kwh lithium iron phosphate battery pack. This product can be used in conjunction with electricity, so that electricity consumption can be adjusted. This product supports a variety of application modes, such as PV self-use surplus power to grid, peak shaving and valley filling, standby power supply, etc. The specific operation logic is as follows.

2.1 PV Self-use Surplus Power to Grid

Under the condition of good illumination in the daytime, the DC power from PV panel is changed into AC through inverter to supply power for household load. If the household load cannot run out of photovoltaic power, the remaining power will be stored in the battery. If the battery is full, photovoltaic power will be supplied to the grid. In the night or rainy days, photovoltaic cannot generate electricity. The battery supplies power to the home load through an inverter. If the battery SOC is low, the household load will take power from the grid.

2.2 Peak Shaving and Valley Filling

In some countries and regions where peak valley time of use price is implemented, if the difference between peak price and low price is large, the application mode of peak shaving and valley filling can be adopted in energy storage system. In the low electricity price period, the energy storage system is charged; in the peak period of electricity price, the energy storage system supplies power to the household load. It can avoid users using too much power grid when the electricity price is high and save energy expenditure.

2.3 Standby Power Supply



In some extreme weather (such as tornadoes, typhoons, hail), or substation operation failure, power supply will be interrupted. If the energy storage system is installed, the user can still enjoy sufficient power guarantee under this situation.

3.Product Specification

N	General Parameter	UPS B23	UPS B51
1	Nominal Voltage	256V	512.5V
2	Rated Capacity (Ah)	100	100
3	Cell Brand (LFP-3.2V)	EVE100AH	EVE100AH
4	System configuration	80S1P	160S1P
5	Battery single box number	5	10
6	Rate power	25.6kWh	51.2kWh
7	Charge Cut-off Voltage	278.4V	556.8V
8	Discharge Cut-off Voltage	216V	432V
9	Recommended Current	50A	50A
10	Maximum Charging Current	100A	100A
11	Maximum Discharging Current	100A	100A
12	Communication protocol	CAN / DRY	
13	Host software protocol	CAN (250Kb/s)	
14	Operation Temperature Range	Charge:0~55°C	
15		Discharge: -20~60°C	
16	Storage Temperature	0°C~25°C	
17	Number of Cycles	5000, SOC >=80%	
16	Internal Impedance	≤1Ω	

Note: Parameters can be adjusted according to customer requirements

3.1Packing List

Battery Pack	Positive and Negative Battery Output Cable	Dry Contact Cable
		

4. Battery Drawing

UPS B23	UPS B51
	
	
<p>Product size :476*660*1110mm</p>	<p>Product size :476*660*1855mm</p>

5. System Installation Instructions

5.1 Installation location

Make sure that the installation location meets the following conditions:

- The building is designed to withstand earthquakes.
- Far away from the sea to avoid salt water and humidity.
- The floor is flat.
- No flammable or explosive materials nearby.
- Optimal ambient temperature is between 25°C and 55°C.

- Temperature and humidity stay at a constant level.
- Minimal dust and dirt in the area.
- No corrosive gases present, including ammonia and acid vapor.

BSL Battery are IPX4 waterproof, so the system could be installed indoor. If the ambient temperature is outside the operating range, battery will protect itself by shutting down. The system optimal operate temperature is 25°C to 55°C. Frequent exposure to severe operating condition would exacerbate the performance and lifetime of the system.







NOTICE

Make sure that the cross-sectional area of charging cables is 25 to 35 mm²

A breaker between BSL battery and inverter was recommended to install and the breakers min. current should meet twice the rated current of the system or following with local regulations.

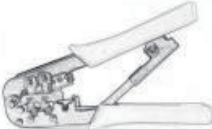
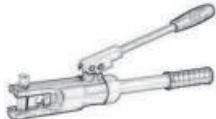
5.2 Installation Tools

To install the battery pack, those following tools are probably required:

			
Phillips screwdriver	Torque wrench	Cable crimper	Wire clamp
			
Voltmeter	Tape measure	Drill	Flat-head screwdriver



Insulated glove

Safety goggles

Safety shoes

5.3 Installation steps

Step 1:

When receiving the product, first check whether all parts are complete, if not, please report to the Dealer.

Step 2:

Choose a suitable installation location and require the system pack to be placed at a safe.

Step 3:

Turn clockwise the DC circuit breaker.

Step 4:

Click the Metal circular switch.

6. Appendix 1

When the equipment manufacturer confirms that it is necessary for customer to set the battery parameter, it can authorize to provide the customer with the host software and operating instructions.



CAN Serial port communication device

Host soft operation:



7.Appendix2

Abnormal Situation Addressing

1. What if the system does not work properly after power on?

A: The most direct way is to check the LCD Displaying of the inverter, through the LCD Displaying to find the fault phenomenon, causes can be roughly analyzed from the LCD Displaying interface prompt alarm, protection, fault, and other information, it can also provide necessary reference for further testing.

2.What is the Battery Failures includes?

- 1) Sampling failure: analog front-end and main control chip communication failure. When the fault occurs, the charge and discharge function is turned off, and the fault alarm can be automatically cleared after the fault is cleared.
- 2) Temperature NTC failure mainly detects whether the temperature NTC is short-circuited or disconnected. When the fault occurs, the charge and discharge function is turned off, and the fault alarm can be automatically cleared after the fault is cleared.
- 3) Cell failure: the voltage difference of the cell exceeds 1V, or the difference between the total voltage detection voltage and the sum of single cell voltage is more than 5V, or the minimum voltage is less than 0.5V. The voltage sampling line disconnect also reports the same fault. When the fault is cleared, the fault alarm can be automatically cleared.

Product Responsibilities and Consulting

We will not be liable for the accidents resulting from operation breaking this specification and user manual.

We will not send separate notice, provided that the contents of this specification are changed due to improvement of product quality or technological upgrading, provided that you want to understand the latest information of this product, please contact us.

The shelf life of this product is within 60 months after it is delivered; we will maintain the product, which is in the warranty period for free of charge, if it has any product quality problems within the specified operation range.

we may replace the relevant parts, if we fail to maintain it, to achieve the purpose of sustainable use without performance reduction; our after-sales service personnel will propose the specific maintenance and troubleshooting methods.

In case of any questions, please contact us.

WARRANTY CARD			
Product Name		Model Number	
BATCH NO.		Shipping Date	
The Buyer		Phone	
Address			
If a device becomes defective during the agreed warranty period, please report the defective device situation to the original manufacturer with this warranty card. Supplier or end users required to send the warranty claim form to the original manufacturer or authorized service partner with all the necessary information. Customers must present this warranty card, battery purchasing invoice, extension warranty letter if applicable, and other related materials as well if required. It is the responsibility of the warranty holder to substantiate the warranty claim and show that the conditions are met. Please note the original manufacturer reserve the ultimate explanation right on this warranty card.			

THANK YOU FOR CHOOSING
LET'S DEVELOP TRUST AND BUSINESS