

# ESS-BATT-215C

## Commercial & Industrial Energy Storage Systems

215 kWh – 2 MWh



High Yield



Easy Maintenance

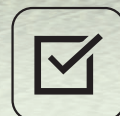

High Performance



Safe and Reliable

## Application Topology

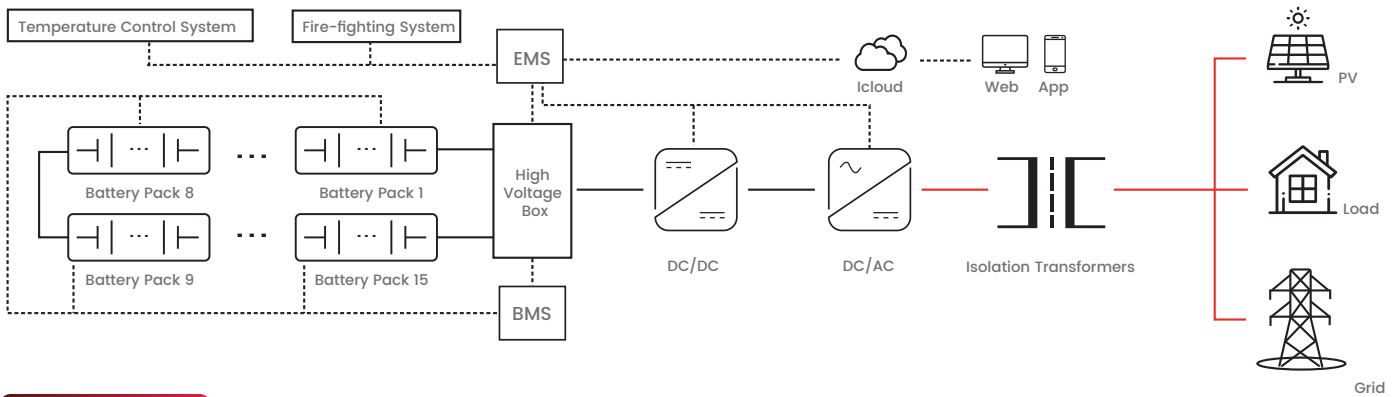

## Specification

Model Number	ESS-BATT-215C
Series and Parallel	16S1P*15=240S1P
Cooling Methods	Air cooling
Rated Capacity	280Ah
Rated voltage	DC768V
Operating Voltage Range	600V~876V
Voltage Range	672V~840V
Rated Energy	215kWh
Rated Charge Current	140A
Rated Discharge Current	140A
Peak Current	560A(25°C, SOC50%, 10S)
Protection Level	IP54
Firefighting Configuration	Pack level + Aerosol
Discharge Temp.	-20°C~55°C
Charge Temp.	0°C~55°C
Storage Temp.	0°C~35°C
Dimension(mm)	1150*1100*2300(±10)
Weight(kg)	2330

