



BSL Series

B-LFP36-100

to replace lead acid GEL or AGM



PRODUCT FEATURES

Designed for Marine/RV/UPS/Lawn Mover/Fish Finder/Access Control Power Energy Storage House Alarm Security applications. BSLBATT's 36V 3840 Wh lithium batteries last up to four times longer than lead-acid batteries. They are maintenance-free, lightweight, and easy to operate.

Our B-LFP36-100 is equipped with the industry's leading LFP batteries, the safest lithium battery chemistry available today. This makes it ideal for deep-cycle applications.

CHARGE AND DISCHARGE CURVE

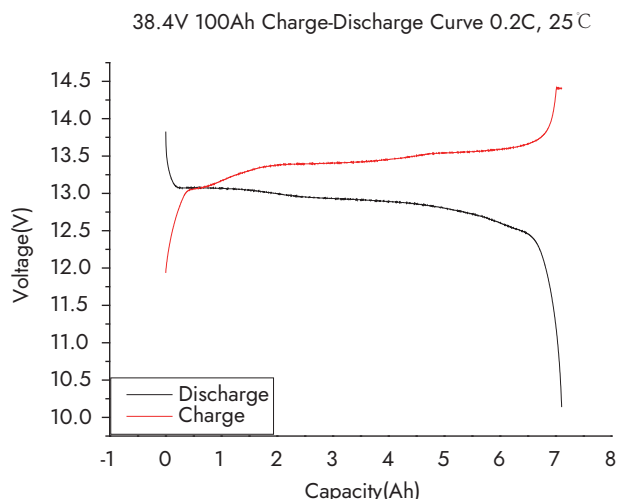

DIMENSION

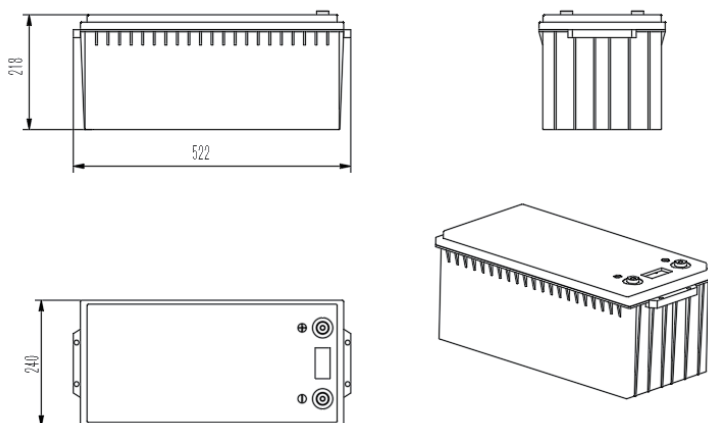

Battery Model **B-LFP36-100**

Nominal Voltage	38.4 V
Typical Capacity	100 Ah(At 0.2C discharge rate)
Energy	3840 Wh

Discharge

Working Current	0.5 C
Maximum Current	1 C
Cut-off Voltage	About 30 V

Charge

Voltage	43.2 ± 0.1 V
Working Current	0.5 C
Max Charging Current	≤ 1 C
Charge Mode	CC/CV, please use special lithium charger
Charging Cut-off Current	About 5 A

Operation Temperature

Charge	0°C ~ +55°C
Discharge	-20°C ~ +60°C

Additional Data

Storage Temperature	-20°C ~ +45°C
Discharging Inner Resistance	≤ 60 mΩ
Protection Function	Overcharge, over-discharge, over-current, short circuit and other protection functions
Output Mode	M8 Terminal
Shell Material	ABS
Weight	About 28.5 Kg (Single weight)
Dimension (L*W*H)	522*240*218 (±2) mm
Cycle	≥3500, 80%DOD (0.2C, 25°C)

Note: Parameters can be adjusted according to customer requirements



Facebook



Linkedin



Tiktok



Instagram



Youtube



Drop-in Replacement



Tier One, A+ LiFePO4 Cell Composition



5 Years Warranty Guarantee



Smart Hardware & Software Design



Long Service Life



Eco-Friendly